

CHAPTER 13

NONPOTABLE WATER SYSTEMS

User note:

About this chapter: Storm water and some liquid waste from a building can be a source of nonpotable water that can be used to reduce the volume of potable water supplied to the building. Chapter 13 provides the requirements for storage, treatment and distribution of this resource. This chapter also regulates the piping systems for reclaimed water supplied by a wastewater treatment facility.

SECTION 1301 GENERAL

1301.1 Scope. The provisions of Chapter 13 shall govern the materials, design, construction and installation of systems for the collection, storage, treatment and distribution of nonpotable water. The use and application of nonpotable water shall comply with laws, rules and ordinances applicable in the jurisdiction.

1301.2 Water quality. Nonpotable water for each end use application shall meet the minimum water quality requirements as established for the intended application by the laws, rules and ordinances applicable in the jurisdiction. Where nonpotable water from different sources is combined in a system, the system shall comply with the most stringent of the requirements of this code that are applicable to such sources.

1301.2.1 Residual disinfectants. Where chlorine is used for disinfection, the nonpotable water shall contain not more than 4 ppm (4mg/L) of chloramines or free chlorine when tested in accordance with ASTM D1253. Where ozone is used for disinfection, the nonpotable water shall not contain gas bubbles having elevated levels of ozone at the point of use.

Exception: Reclaimed water sources shall not be required to comply with these requirements.

1301.2.2 Filtration required. Nonpotable water utilized for water closet and urinal flushing applications shall be filtered by a 100-micron or finer filter.

Exception: Reclaimed water sources shall not be required to comply with these requirements.

1301.3 Signage required. Nonpotable water outlets such as hose connections, open ended pipes and faucets shall be identified at the point of use for each outlet with signage that reads as follows: "Nonpotable water is utilized for [application name]. CAUTION: NONPOTABLE WATER – DO NOT DRINK." The words shall be legibly and indelibly printed on a tag or sign constructed of corrosion-resistant waterproof material or shall be indelibly printed on the fixture. The letters of the words shall be not less than 0.5 inch (12.7 mm) in height and in colors in contrast to the background on which they are applied. In addition to the required wordage, the pictograph shown in Figure 1301.3 shall appear on the signage required by this section.

1301.4 Permits. Permits shall be required for the construction, installation, alteration and repair of nonpotable water systems. Construction documents, engineering calculations,

diagrams and other such data pertaining to the nonpotable water system shall be submitted with each permit application.

1301.5 Potable water connections. Where a potable system is connected to a nonpotable water system, the potable water supply shall be protected against backflow in accordance with Section 608.

1301.6 Components and materials. Piping, plumbing components and materials used in collection and conveyance systems shall be of material approved by the manufacturer for the intended application.

1301.7 Insect and vermin control. The system shall be protected to prevent the entrance of insects and vermin into storage tanks and piping systems. Screen materials shall be compatible with contacting system components and shall not accelerate the corrosion of system components.

1301.8 Freeze protection. Where sustained freezing temperatures occur, provisions shall be made to keep storage tanks and the related piping from freezing.

1301.9 Nonpotable water storage tanks. Nonpotable water storage tanks shall comply with Sections 1301.9.1 through 1301.9.10.



FIGURE 1301.3
PICTOGRAPH—DO NOT DRINK

1301.9.1 Location. Any storage tank or portion thereof that is above grade shall be protected from direct exposure to sunlight by one of the following methods:

1. Tank construction using opaque, UV-resistant materials such as heavily tinted plastic, fiberglass, lined metal, concrete, wood, or painted to prevent algae growth.
2. Specially constructed sun barriers.
3. Installation in garages, crawl spaces or sheds.

1301.9.2 Materials. Where collected on site, water shall be collected in an approved tank constructed of durable, nonabsorbent and corrosion-resistant materials. The storage tank shall be constructed of materials compatible with any disinfection systems used to treat water upstream of the tank and with any systems used to maintain water quality in the tank. Wooden storage tanks that are not equipped with a makeup water source shall be provided with a flexible liner.

1301.9.3 Foundation and supports. Storage tanks shall be supported on a firm base capable of withstanding the weight of the storage tank when filled to capacity. Storage tanks shall be supported in accordance with the *International Building Code*.

1301.9.3.1 Ballast. Where the soil can become saturated, an underground storage tank shall be ballasted, or otherwise secured, to prevent the tank from floating out of the ground when empty. The combined weight of the tank and hold down ballast shall meet or exceed the buoyancy force of the tank. Where the installation requires a foundation, the foundation shall be flat and shall be designed to support the weight of the storage tank when full, consistent with the bearing capability of adjacent soil.

1301.9.3.2 Structural support. Where installed below grade, storage tank installations shall be designed to withstand earth and surface structural loads without damage and with minimal deformation when empty or filled with water.

1301.9.4 Makeup water. Where an uninterrupted supply is required for the intended application, potable or reclaimed water shall be provided as a source of makeup water for the storage tank. The makeup water supply shall be protected against backflow in accordance with Section 608. A full-open valve located on the makeup water supply line to the storage tank shall be provided. Inlets to the storage tank shall be controlled by fill valves or other automatic supply valves installed to prevent the tank from overflowing and to prevent the water level from dropping below a predetermined point. Where makeup water is provided, the water level shall not be permitted to drop below the source water inlet or the intake of any attached pump.

1301.9.5 Overflow. The storage tank shall be equipped with an overflow pipe having a diameter not less than that shown in Table 606.5.4. The overflow pipe shall be protected from insects or vermin and shall discharge in a manner consistent with storm water runoff requirements of the jurisdiction. The overflow pipe shall discharge at a suf-

ficient distance from the tank to avoid damaging the tank foundation or the adjacent property. Drainage from overflow pipes shall be directed to prevent freezing on roof walkways. The overflow drain shall not be equipped with a shutoff valve. A cleanout shall be provided on each overflow pipe in accordance with Section 708.

1301.9.6 Access. Not less than one access opening shall be provided to allow inspection and cleaning of the tank interior. Access openings shall have an approved locking device or other approved method of securing access. Below-grade storage tanks, located outside of the building, shall be provided with a manhole either not less than 24 inches (610 mm) square or with an inside diameter not less than 24 inches (610 mm). Manholes shall extend not less than 4 inches (102 mm) above ground or shall be designed to prevent water infiltration. Finished grade shall be sloped away from the manhole to divert surface water. Manhole covers shall be secured to prevent unauthorized access. Service ports in manhole covers shall be not less than 8 inches (203 mm) in diameter and shall be not less than 4 inches (102 mm) above the finished grade level. The service port shall be secured to prevent unauthorized access.

Exception: Treated-water storage tanks that are less than 800 gallons (3028 L) in volume and installed below grade shall not be required to be equipped with a manhole provided that the tank has a service port of not less than 8 inches (203 mm) in diameter.

1301.9.7 Venting. Storage tanks shall be provided with a vent sized in accordance with Chapter 9 and based on the aggregate diameter of all tank influent pipes. The reservoir vent shall not be connected to sanitary drainage system vents. Vents shall be protected from contamination by means of an approved cap or U-bend installed with the opening directed downward. Vent outlets shall extend not less than 4 inches (102 mm) above grade or as necessary to prevent surface water from entering the storage tank. Vent openings shall be protected against the entrance of vermin and insects in accordance with the requirements of Section 1301.7.

1301.9.8 Draining of tanks. Tanks shall be provided with a means of emptying the contents for the purpose of service or cleaning. Tanks shall be drained by using a pump or by a drain located at the lowest point in the tank. The tank drain pipe shall discharge as required for overflow pipes and shall not be smaller in size than specified in Table 606.5.7. Not less than one cleanout shall be provided on each drain pipe in accordance with Section 708.

1301.9.9 Marking and signage. Each nonpotable water storage tank shall be labeled with its rated capacity. The contents of storage tanks shall be identified with the words "CAUTION: NONPOTABLE WATER - DO NOT DRINK." Where an opening is provided that could allow the entry of personnel, the opening shall be marked with the words, "DANGER - CONFINED SPACE." Markings shall be indelibly printed on the tank or on a tag or sign constructed of corrosion-resistant waterproof material that is mounted on the tank. The letters of the words shall be

TABLE 606.5.4
SIZES FOR OVERFLOW PIPES FOR WATER SUPPLY TANKS

MAXIMUM CAPACITY OF WATER SUPPLY LINE TO TANK (gpm)	DIAMETER OF OVERFLOW PIPE (Inches)
0 - 50	2
50 - 150	2½
150 - 200	3
200 - 400	4
400 - 700	5
700 - 1,000	6
Over 1,000	8

For SI: 1 inch = 25.4 mm, 1 gallon per minute = 3.785 L/m.

TABLE 606.5.7
SIZE OF DRAIN PIPES FOR WATER TANKS

TANK CAPACITY (gallons)	DRAIN PIPE (Inches)
Up to 750	1
751 to 1,500	1½
1,501 to 3,000	2
3,001 to 5,000	2½
5,000 to 7,500	3
Over 7,500	4

For SI: 1 inch = 25.4 mm, 1 gallon = 3.785 L.

not less than 0.5 inch (12.7 mm) in height and shall be of a color in contrast with the background on which they are applied.

1301.9.10 Storage tank tests. Storage tanks shall be tested in accordance with the following:

Storage tanks shall be filled with water to the overflow line prior to and during inspection. Seams and joints shall be left exposed and the tank shall remain water tight without leakage for a period of 24 hours.

1. After 24 hours, supplemental water shall be introduced for a period of 15 minutes to verify proper drainage of the overflow system and that there are no leaks.
2. The tank drain shall be observed for proper operation.
3. The makeup water system shall be observed for proper operation and successful automatic shut-off of the system at the refill threshold shall be verified.

1301.10 System abandonment. If the owner of an on-site nonpotable water reuse system or rainwater collection and conveyance system elects to cease use of, or fails to properly maintain such system, the system shall be abandoned and shall comply with the following:

1. All system piping connecting to a utility-provided water system shall be removed or disabled.
2. The distribution piping system shall be replaced with an approved potable water supply piping system. Where an existing potable pipe system is already in place, the fixtures shall be connected to the existing system.
3. The storage tank shall be secured from accidental access by sealing or locking tank inlets and access points, or filling with sand or equivalent.

1301.11 Trenching requirements for nonpotable water piping. Nonpotable water collection and distribution piping and reclaimed water piping shall be separated from the building sewer and potable water piping underground by 5 feet (1524 mm) of undisturbed or compacted earth. Nonpotable water collection and distribution piping shall not be located in, under or above cesspools, septic tanks, septic tank drainage fields or seepage pits. Buried nonpotable water piping shall comply with the requirements of Section 306.

Exceptions:

1. The required separation distance shall not apply where the bottom of the nonpotable water pipe within 5 feet (1524 mm) of the sewer is not less than 12 inches (305 mm) above the top of the highest point of the sewer and the pipe materials conform to Table 702.3.
2. The required separation distance shall not apply where the bottom of the potable water service pipe within 5 feet (1524 mm) of the nonpotable water pipe is not less than 12 inches (305 mm) above the top of the highest point of the nonpotable water pipe and the pipe materials comply with the requirements of Table 605.4.

3. Nonpotable water pipe is permitted to be located in the same trench with a building sewer, provided that such sewer is constructed of materials that comply with the requirements of Table 702.2.
4. The required separation distance shall not apply where a nonpotable water pipe crosses a sewer pipe, provided that the pipe is sleeved to not less than 5 feet (1524 mm) horizontally from the sewer pipe centerline on both sides of such crossing, with pipe materials that comply with Table 702.2.
5. The required separation distance shall not apply where a potable water service pipe crosses a nonpotable water pipe, provided that the potable water service pipe is sleeved for a distance of not less than 5 feet (1524 mm) horizontally from the centerline of the nonpotable pipe on both sides of such crossing, with pipe materials that comply with Table 702.2.
6. Irrigation piping located outside of a building and downstream of the backflow preventer is not required to meet the trenching requirements where nonpotable water is used for outdoor applications.

1301.12 Outdoor outlet access. Sillcocks, hose bibbs, wall hydrants, yard hydrants and other outdoor outlets supplied by nonpotable water shall be located in a locked vault or shall be operable only by means of a removable key.

SECTION 1302

ON-SITE NONPOTABLE WATER REUSE SYSTEMS

1302.1 General. The provisions of ASTM E2635 and Section 1302 shall govern the construction, installation, alteration and repair of on-site nonpotable water reuse systems for the collection, storage, treatment and distribution of on-site sources of nonpotable water as permitted by the jurisdiction.

1302.2 Sources. On-site nonpotable water reuse systems shall collect waste discharge from only the following sources: bathtubs, showers, lavatories, clothes washers and laundry trays. Where approved and as appropriate for the intended application, water from other nonpotable sources shall be collected for reuse by on-site nonpotable water reuse systems.

1302.2.1 Prohibited sources. Waste water containing urine or fecal matter shall not be diverted to on-site nonpotable water reuse systems and shall discharge to the sanitary drainage system of the building or premises in accordance with Chapter 7. Reverse osmosis system reject water, water softener discharge water, kitchen sink waste water, dishwasher waste water and waste water discharged from wet-hood scrubbers shall not be collected for reuse in an on-site nonpotable water reuse system.

1302.3 Traps. Traps serving fixtures and devices discharging waste water to on-site nonpotable water reuse systems shall comply with Section 1002.4.

1302.4 Collection pipe. On-site nonpotable water reuse systems shall utilize drainage piping approved for use in plumbing drainage systems to collect and convey untreated water for reuse. Vent piping approved for use in plumbing venting systems shall be utilized for vents in the gray water system.

NONPOTABLE WATER SYSTEMS

Collection and vent piping materials shall comply with Section 702.

1302.4.1 Installation. Collection piping conveying untreated water for reuse shall be installed in accordance with Section 704.

1302.4.2 Joints. Collection piping conveying untreated water for reuse shall utilize joints approved for use with the distribution piping and appropriate for the intended applications as specified in Section 705.

1302.4.3 Size. Collection piping conveying untreated water for reuse shall be sized in accordance with drainage sizing requirements specified in Section 710.

1302.4.4 Labeling and marking. Additional marking of collection piping conveying untreated water for reuse shall not be required beyond that required for sanitary drainage, waste and vent piping by Chapter 7.

1302.5 Filtration. Untreated water collected for reuse shall be filtered as required for the intended end use. Filters shall be provided with access for inspection and maintenance. Filters shall utilize a pressure gauge or other approved method to provide indication when a filter requires servicing or replacement. Filters shall be installed with shutoff valves immediately upstream and downstream to allow for isolation during maintenance.

1302.6 Disinfection and treatment. Where the intended application for nonpotable water collected on site for reuse requires disinfection or other treatment or both, it shall be disinfected as needed to ensure that the required water quality is delivered at the point of use. Nonpotable water collected on site containing untreated gray water shall be retained in collection reservoirs for not longer than 24 hours.

1302.6.1 Gray water used for fixture flushing. Gray water used for flushing water closets and urinals shall be disinfected and treated by an on-site water reuse treatment system complying with NSF 350.

1302.7 Storage tanks. Storage tanks utilized in on-site nonpotable water reuse systems shall comply with Sections 1301.9, 1302.7.1 and 1302.7.2.

1302.7.1 Location. Storage tanks shall be located with a minimum horizontal distance between various elements as indicated in Table 1302.7.1.

1302.7.2 Outlets. Outlets shall be located not less than 4 inches (102 mm) above the bottom of the storage tank and shall not skim water from the surface.

1302.8 Valves. Valves shall be supplied on on-site nonpotable water reuse systems in accordance with Sections 1302.8.1 and 1302.8.2.

1302.8.1 Bypass valve. One three-way diverter valve listed and labeled to NSF 50 or other approved device shall be installed on collection piping upstream of each storage tank, or drainfield, as applicable, to divert untreated on-site reuse sources to the sanitary sewer to allow servicing and inspection of the system. Bypass valves shall be installed downstream of fixture traps and vent connections. Bypass valves shall be marked to indicate the direction of flow, connection and storage tank or drainfield connection. Bypass valves shall be provided with access that allows for removal. Two shutoff valves shall not be installed to serve as a bypass valve.

1302.8.2 Backwater valve. One or more backwater valves shall be installed on each overflow and tank drain pipe. Backwater valves shall be in accordance with Section 714.

1302.9 Pumping and control system. Mechanical equipment including pumps, valves and filters shall be easily accessible and removable in order to perform repair, maintenance and cleaning. The minimum flow rate and flow pressure delivered by the pumping system shall be appropriate for the application and in accordance with Section 604.

1302.10 Water pressure-reducing valve or regulator. Where the water pressure supplied by the pumping system exceeds 80 psi (552 kPa) static, a pressure-reducing valve shall be installed to reduce the pressure in the nonpotable water distribution system piping to 80 psi (552 kPa) static or less. Pressure-reducing valves shall be specified and installed in accordance with Section 604.8.

1302.11 Distribution pipe. Distribution piping utilized in on-site nonpotable water reuse systems shall comply with Sections 1302.11.1 through 1302.11.3.

Exception: Irrigation piping located outside of the building and downstream of a backflow preventer.

1302.11.1 Materials, joints and connections. Distribution piping shall conform to the standards and requirements specified in Section 605.

TABLE 1302.7.1
LOCATION OF NONPOTABLE WATER REUSE STORAGE TANKS

ELEMENT	MINIMUM HORIZONTAL DISTANCE FROM STORAGE TANK (feet)
Critical root zone (CRZ) of protected trees	2
Lot line adjoining private lots	5
Seepage pits	5
Septic tanks	5
Water wells	50
Streams and lakes	50
Water service	5
Public water main	10

For SI: 1 foot = 304.8 mm.

1302.11.2 Design. On-site nonpotable water reuse distribution piping systems shall be designed and sized in accordance with Section 604 for the intended application.

1302.11.3 Marking. On-site nonpotable water distribution piping labeling and marking shall comply with Section 608.9.

1302.12 Tests and inspections. Tests and inspections shall be performed in accordance with Sections 1302.12.1 through 1302.12.6.

1302.12.1 Collection pipe and vent test. Drain, waste and vent piping used for on-site water reuse systems shall be tested in accordance with Section 312.

1302.12.2 Storage tank test. Storage tanks shall be tested in accordance with Section 1301.9.10.

1302.12.3 Water supply system test. The testing of makeup water supply piping and distribution piping shall be conducted in accordance with Section 312.5.

1302.12.4 Inspection and testing of backflow prevention assemblies. The testing of backflow preventers and backwater valves shall be conducted in accordance with Section 312.10.

1302.12.5 Inspection of vermin and insect protection. Inlets and vents to the system shall be inspected to verify that each is protected to prevent the entrance of insects and vermin into the storage tank and piping systems in accordance with Section 1301.7.

1302.12.6 Water quality test. The quality of the water for the intended application shall be verified at the point of use in accordance with the requirements of the jurisdiction.

1302.13 Operation and maintenance manuals. Operation and maintenance materials shall be supplied with nonpotable on-site water reuse systems in accordance with Sections 1302.13.1 through 1302.13.4.

1302.13.1 Manual. A detailed operations and maintenance manual shall be supplied in hardcopy form with all systems.

1302.13.2 Schematics. The manual shall include a detailed system schematic, and the locations and a list of all system components, including manufacturer and model number.

1302.13.3 Maintenance procedures. The manual shall provide a schedule and procedures for all system components requiring periodic maintenance. Consumable parts, including filters, shall be noted along with part numbers.

1302.13.4 Operations procedures. The manual shall include system startup and shutdown procedures. The manual shall include detailed operating procedures for the system.

SECTION 1303 NONPOTABLE RAINWATER COLLECTION AND DISTRIBUTION SYSTEMS

1303.1 General. The provisions of Section 1303 shall govern the construction, installation, alteration and repair of rainwa-

ter collection and conveyance systems for the collection, storage, treatment and distribution of rainwater for nonpotable applications, as permitted by the jurisdiction.

1303.1.1 Fire protection systems. The storage, treatment and distribution of nonpotable water to be used for fire protection systems shall be in accordance with the *International Fire Code*.

1303.2 Collection surface. Rainwater shall be collected only from above-ground impervious roofing surfaces constructed from *approved* materials and where *approved*, vehicular parking or pedestrian walking surfaces.

1303.3 Debris excluders. Downspouts and leaders shall be connected to a debris excluder or equivalent device that is designed to remove leaves, sticks, pine needles and similar debris to prevent such from entering the storage tank.

1303.4 First-flush diverter. First-flush diverters shall operate automatically and shall not rely on manually operated valves or devices. Diverted rainwater shall not be drained to the roof surface, and shall be discharged in a manner consistent with the storm water runoff requirements of the jurisdiction. First-flush diverters shall be provided with *access* for maintenance and service.

1303.5 Roof gutters and downspouts. Gutters and downspouts shall be constructed of materials that are compatible with the collection surface and the rainwater quality for the desired end use. Joints shall be water tight.

1303.5.1 Slope. Roof gutters, leaders and rainwater collection piping shall slope continuously toward collection inlets. Gutters and downspouts shall have a slope of not less than $\frac{1}{8}$ inch per foot (10.4 mm/m) along their entire length, and shall not permit the collection or pooling of water at any point.

Exception: Siphonic drainage systems installed in accordance with the manufacturer's instructions shall not be required to have a slope.

1303.5.2 Size. Gutters and downspouts shall be installed and sized in accordance with Section 1106.6 and local rainfall rates.

1303.5.3 Cleanouts. Cleanouts shall be provided in the water conveyance system to allow *access* to all filters, flushes, pipes and downspouts.

1303.6 Drainage. Water drained from the roof washer or debris excluder shall not be drained to the sanitary sewer. Such water shall be diverted from the storage tank and discharge in a location that will not cause erosion or damage to property in accordance with the *International Building Code*. Roof washers and debris excluders shall be provided with an automatic means of self-draining between rain events, and shall not drain onto roof surfaces.

1303.7 Collection pipe. Rainwater collection and conveyance systems shall utilize drainage piping *approved* for use within plumbing drainage systems to collect and convey captured rainwater. Vent piping *approved* for use within plumbing venting systems shall be utilized for vents within the rainwater system. Collection and vent piping materials shall comply with Section 702.

tection against backflow and contamination of the water supply system.

608.3.1 Special equipment, water supply protection.

The water supply for hospital fixtures shall be protected against backflow with a reduced pressure principle backflow prevention assembly, an atmospheric or spill-resistant vacuum breaker assembly, or an *air gap*. Vacuum breakers for bedpan washer hoses shall not be located less than 5 feet (1524 mm) above the floor. Vacuum breakers for hose connections in health care or laboratory areas shall be not less than 6 feet (1829 mm) above the floor.

608.4 Potable water handling and treatment equipment.

Water pumps, filters, softeners, tanks and other appliances and devices that handle or treat potable water to be supplied to the potable water distribution system shall be located to prevent contamination from entering the appliances and devices. Overflow, relief valve and waste discharge pipes from such appliances and devices shall terminate through an *air gap*.

608.5 Water service piping. Water service piping shall be protected in accordance with Sections 603.2 and 603.2.1.

608.6 Chemicals and other substances. Chemicals and other substances that produce either toxic conditions, taste, odor or discoloration in a potable water system shall not be introduced into, or utilized in, such systems.

608.7 Cross connection control. Cross connections shall be prohibited, except where *approved* backflow prevention assemblies, backflow prevention devices or other means or methods are installed to protect the potable water supply.

608.7.1 Private water supplies. Cross connections between a private water supply and a potable public supply shall be prohibited.

608.8 Valves and outlets prohibited below grade. Potable water outlets and combination stop-and-waste valves shall not be installed underground or below grade. A freezeproof yard hydrant hydrant that drains the riser into the ground shall be considered as having a stop-and-waste valve below grade.

Exception: Freezeproof yard hydrants that drain the riser into the ground shall be permitted to be installed, provided that the potable water supply to such hydrants is protected in accordance with Section 613.13.2 or 613.13.5, and the hydrants and the piping from the backflow preventer to the hydrant are identified in accordance with Section 608.9.

608.9 Identification of nonpotable water systems. Where nonpotable water systems are installed, the piping conveying the nonpotable water shall be identified either by color marking, metal tags or tape in accordance with Sections 608.9.1 through 608.9.2.3.

608.9.1 Signage required. Nonpotable water outlets, such as hose connections, open ended pipes and faucets, shall be identified with signage that reads as follows: "Nonpotable water is utilized for [application name]. **CAUTION: NONPOTABLE WATER - DO NOT DRINK.**"

The words shall be legibly and indelibly printed on a tag or sign constructed of corrosion-resistant waterproof material or shall be indelibly printed on the fixture. The letters of the words shall be not less than 0.5 inch (12.7 mm) in

height and in colors in contrast to the background on which they are applied. In addition to the required wordage, the pictograph shown in Figure 608.9.1 shall appear on the required signage.



FIGURE 608.9.1
PICTOGRAPH—DO NOT DRINK

608.9.2 Distribution pipe labeling and marking. Nonpotable distribution piping shall be purple in color and shall be embossed, or integrally stamped or marked, with the words: "CAUTION: NONPOTABLE WATER - DO NOT DRINK" or the piping shall be installed with a purple identification tape or wrap. Pipe identification shall include the contents of the piping system and an arrow indicating the direction of flow. Hazardous piping systems shall also contain information addressing the nature of the hazard. Pipe identification shall be repeated at intervals not exceeding 25 feet (7620 mm) and at each point where the piping passes through a wall, floor or roof. Lettering shall be readily observable within the room or space where the piping is located.

608.9.2.1 Color. The color of the pipe identification shall be discernable and consistent throughout the building. The color purple shall be used to identify reclaimed, rain and gray water distribution systems.

608.9.2.2 Lettering size. The size of the background color field and lettering shall comply with Table 608.9.2.2.

TABLE 608.9.2.2
SIZE OF PIPE IDENTIFICATION

PIPE DIAMETER (inches)	LENGTH BACKGROUND COLOR FIELD (inches)	SIZE OF LETTERS (inches)
3/4 to 1 1/4	8	0.5
1 1/2 to 2	8	0.75
2 1/2 to 6	12	1.25
8 to 10	24	2.5
Over 10	32	3.5

For SI 1 inch = 25.4 mm.

608.9.2.3 Identification tape. Where used, identification tape shall be not less than 3 inches (76 mm) wide and have white or black lettering on a purple field stating "CAUTION: NONPOTABLE WATER – DO NOT DRINK." Identification tape shall be installed on top of nonpotable rainwater distribution pipes, fastened not less than every 10 feet (3048 mm) to each pipe length and run continuously the entire length of the pipe.

608.10 Reutilization prohibited. Water utilized for the heating or cooling of equipment or other processes shall not be returned to the potable water system. Such water shall be discharged into a drainage system through an *air gap* or shall be utilized for nonpotable purposes.

608.11 Reuse of piping. Piping that has been utilized for any purpose other than conveying potable water shall not be utilized for conveying potable water.

608.12 Potable water tanks. Where in contact with potable water intended for drinking water, water tanks, coatings for the inside of tanks and liners for water tanks shall conform to NSF 61. The interior surface of a potable water tank shall not be lined, painted or repaired with any material that changes the taste, odor, color or potability of the water supply when the tank is placed in, or returned to, service.

608.13 Pumps and other appliances. Water pumps, filters, softeners, tanks and other devices that handle or treat potable water shall be protected against contamination.

608.14 Backflow protection. Means of protection against backflow shall be provided in accordance with Sections 609.14.1 through 608.14.9.

608.14.1 Air gap. The minimum required *air gap* shall be measured vertically from the lowest end of a potable water outlet to the *flood level rim* of the fixture or receptacle into which such potable water outlet discharges. *Air gaps* shall comply with ASME A112.1.2 and *air gap* fittings shall comply with ASME A112.1.3. Products that are listed and labeled to ASME A112.1.2 or ASME A112.1.3 shall be considered to be in compliance with this section.

608.14.2 Reduced pressure principle backflow prevention assemblies. Reduced pressure principle backflow prevention assemblies shall conform to ASSE 1013, AWWA C511, CSA B64.4 or CSA B64.4.1. Reduced pressure detector assembly backflow preventers shall conform to ASSE 1047. These devices shall be permitted to be installed where subject to continuous pressure conditions. The relief opening shall discharge by *air gap* and shall be prevented from being submerged.

608.14.3 Backflow preventer with intermediate atmospheric vent. Backflow preventers with intermediate atmospheric vents shall conform to ASSE 1012 or CSA B64.3. These devices shall be permitted to be installed where subject to continuous pressure conditions. The relief opening shall discharge by *air gap* and shall be prevented from being submerged.

608.14.4 Barometric loop. Barometric loops shall precede the point of connection and shall extend vertically to a height of 35 feet (10 668 mm). A barometric loop shall

only be utilized as an atmospheric-type or pressure-type vacuum breaker.

608.14.5 Pressure vacuum breaker assemblies. Pressure vacuum breaker assemblies shall comply with ASSE 1020 or CSA B64.1.2. Spill-resistant vacuum breaker assemblies shall comply with ASSE 1056 or CSA B64.1.3. These assemblies shall be installed with the critical level of the assembly located not less than 12 inches (305 mm) above all downstream piping and outlets. Pressure vacuum breaker assemblies shall not be installed in locations where spillage could cause damage to the structure.

608.14.6 Atmospheric-type vacuum breakers. Pipe-applied atmospheric-type vacuum breakers shall conform to ASSE 1001 or CSA B64.1.1. Hose-connection vacuum breakers shall conform to ASME A112.21.3, ASSE 1011, ASSE 1019, ASSE 1035, ASSE 1052, CSA B64.2, CSA B64.2.1, CSA B64.2.1.1, CSA B64.2.2 or CSA B64.7. These devices shall operate under normal atmospheric pressure when the critical level is installed at the required height.

608.14.7 Double check backflow prevention assemblies. Double check backflow prevention assemblies shall conform to ASSE 1015, CSA B64.5, CSA B64.5.1 or AWWA C510. Double check detector fire protection backflow prevention assemblies shall conform to ASSE 1048. These assemblies shall be capable of operating under continuous pressure conditions.

608.14.8 Chemical dispenser backflow devices. Backflow devices for chemical dispensers shall comply with ASSE 1055 or shall be equipped with an *air gap* fitting.

608.14.9 Dual check backflow preventer. Dual check backflow preventers shall conform to ASSE 1024 or CSA B64.6.

608.15 Location of backflow preventers. Access shall be provided to backflow preventers as specified by the manufacturer's instructions.

608.15.1 Outdoor enclosures for backflow prevention devices. Outdoor enclosures for backflow prevention devices shall comply with ASSE 1060.

608.15.2 Protection of backflow preventers. Backflow preventers shall not be located in areas subject to freezing except where they can be removed by means of unions or are protected from freezing by heat, insulation or both.

608.15.2.1 Relief port piping. The termination of the piping from the relief port or *air gap* fitting of a backflow preventer shall discharge to an *approved* indirect waste receptor or to the outdoors where it will not cause damage or create a nuisance.

608.16 Protection of potable water outlets. Potable water openings and outlets shall be protected against backflow in accordance with Section 608.16.1, 608.16.2, 608.16.3, 608.16.4, 608.16.4.1 or 608.16.4.2.

608.16.1 Protection by air gap. Openings and outlets shall be protected by an *air gap* between the opening and the fixture *flood level rim* as specified in Table 608.16.1. Openings and outlets equipped for hose connection shall be protected by means other than an *air gap*.

Chapter 13: Gray Water Recycling Systems

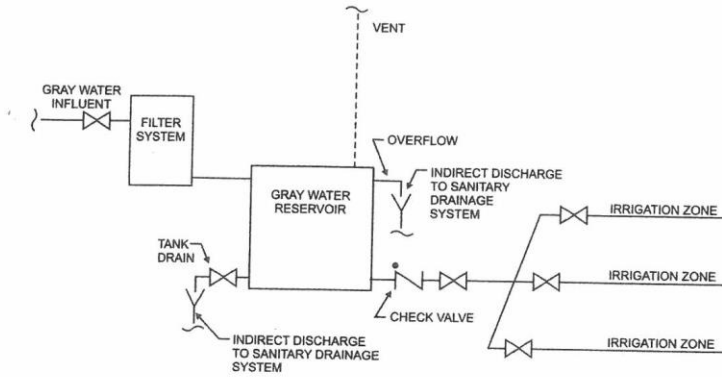

FIGURE 1301.1(1)
GRAY WATER RECYCLING SYSTEM FOR SUBSURFACE LANDSCAPE IRRIGATION

2012 INTERNATIONAL PLUMBING CODE® COMMENTARY

13-1

GRAY WATER RECYCLING SYSTEMS

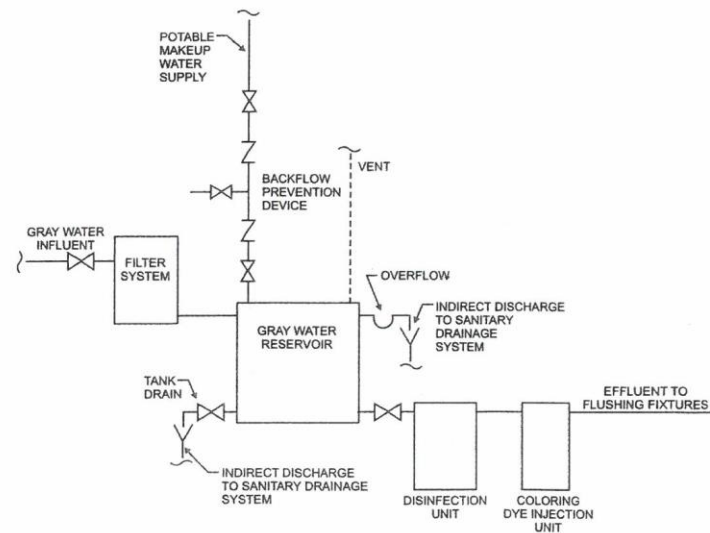

FIGURE 1301.1(2)
GRAY WATER RECYCLING SYSTEM FOR FLUSHING WATER CLOSETS AND URINALS